

# Datasheet

# Si-108 EN

## Ball segment valve - Low noise design (LN)

Edition: 2010-04

<b>Type KVTW LN / KVXW LN</b>	<b>Wafer design</b>
<b>Type KVTF LN / KVXF LN</b>	<b>Flanged design</b>
<b>Nominal pressure</b>	<b>PN 20 - 50</b>
<b>Nominal size</b>	<b>DN 50 - 250 (W) DN 50 - 400 (F)</b>
<b>Material</b>	<b>Stainless steel</b>

- **Low noise level**
- **Control and shut-off valve**
- **One-piece shaft gives a torque transmission free of backlash**
- **Excellent tightness irrespective of differential pressure**
- **Easy maintenance.**

The SOMAS ball segment valve types KVTW LN and KVTF LN, with centrally mounted shaft and KVXW LN and KVXF LN with eccentrically mounted shaft, are designed to reduce noise. KVTW LN and KVXW LN are of wafer design while KVTF LN and KVXF LN are flanged valves.

The valve body is of one-piece design. The shaft device is also in one piece for torque transmission free of backlash. The spring-loaded seat is available in three alternative materials (PTFE, PTFE 53 and HiCo).

Noise reduction is achieved through a low noise trim. This trim is mounted directly to the segment and consists of a number of bars located in a specific pattern that are used to split up the pressure drop across the valve. This results in less pressure recovery, thereby reducing the noise and potential damage due to cavitation. In addition the "LN" trim can tolerate media containing a small amount of fibers or particles.

The SOMAS valves are delivered ready for installation and operation. The valve assemblies are delivered factory tested as complete units with actuators, positioners and accessories.





## Background

Within the process industry and the energy sector there are a number of applications where process data in combination with standard control valves will result in problems such as erosion and high noise level.

These problems are usually related to high flow velocities and/or pressure drops within the valve caused by the severe nature of a given process's requirement.

By using a standard ball segment valve and adding the SOMAS noise reduction device to its segment, many severe noise-producing applications can be solved.

## Theory

The risk of cavitation is high in liquid applications when combined with high-pressure drops.

Cavitation is a two-stage phenomenon caused by the fluid undergoing two changes of state. The initial pressure of the liquid is reduced to a value below its vapour pressure as it passes through a restriction (valve). This pressure reduction causes vapour voids or bubbles to form, the pressure then recovers to a value greater than the liquid's vapour pressure, causing the voids to collapse or implode back into an all-liquid state. The cavitation process is always accompanied by high noise and if left to itself, will cause severe damage to both the control valve as well as its proximate downstream piping and/or fittings. The second stage is the collapse or implosion of these cavities back into an all-liquid state.

In order to visualize how these phenomena occur in control valves, consider a liquid flowing in a piping system in which a restriction such as a concentric orifice has been placed. In this case, the orifice may be considered analogous to a control valve at some fixed opening. Fig. 1 illustrates the pressures and velocities along the flow stream.

As the fluid stream approaches the restriction in the line, its cross-sectional area must decrease in order to pass through the orifice. The velocity is inversely proportional to the stream area and, therefore, must increase. Immediately downstream of the orifice the stream will reach its minimum cross-section and thus its maximum velocity. This point is called the vena contracta. If the velocity is increased sufficiently, the pressure will fall to the vapour pressure, thus permitting the formation of voids in the stream, which is the first stage of cavitation.

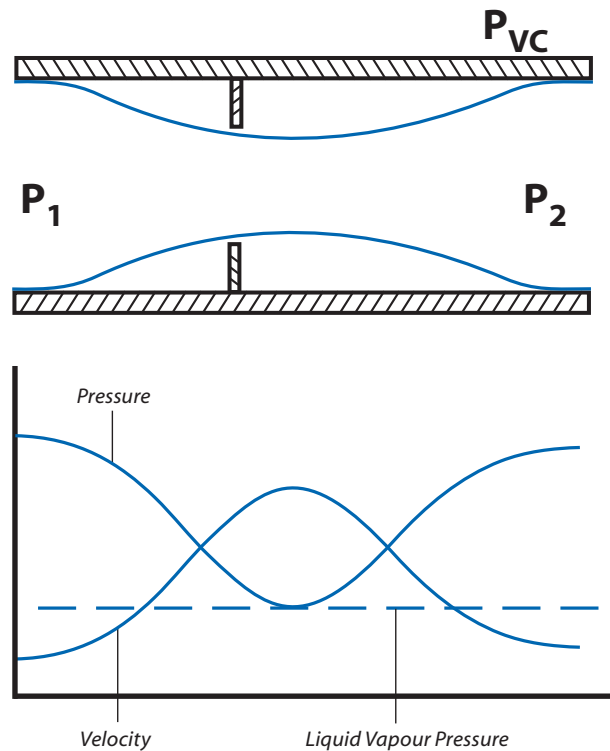

Fig. 1

Downstream of the vena contracta, fluid friction causes the stream to decelerate with resultant increases in both stream cross-section and pressure. This reversal of energy interchange between the velocity and “pressure recovery” plays an important role in valve sizing.

Vapour bubbles, formed by reducing the pressure at the vena contracta to the vapour pressure, cannot exist at increased pressure downstream and are forced to collapse or implode back into the liquid state.

Should the pressure in the downstream piping system be maintained at a level equal to or less than the inlet vapour pressure, the fluid proceeding downstream would have an increased percentage of vapour. The velocity of the stream would continue to increase and the end result would be flashing rather than cavitation.

## Gas

For installations on steam and gas, the noise level is related to high flow velocity due to high differential pressure across the valve. This will normally not influence the lifetime of the valve.

The additional cage on the segment will split up the pressure drop, and the flow velocity inside the valve body will be lower. As a result of this, less noise is generated.

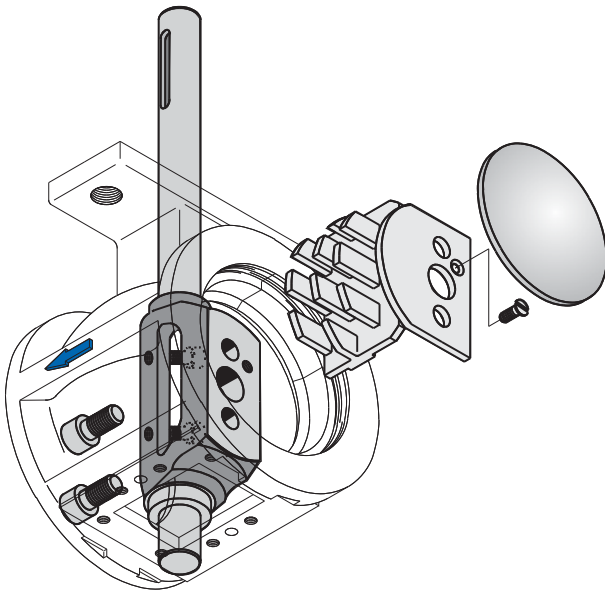

Principal sketch

### Valve description

SOMAS ball segment valves type KVTW LN and KVXW LN are derivatives of the SOMAS standard models KVTW and KVXW. The designation “LN” indicates that the ball segment is equipped with a low noise trim, which is used to split up the pressure drop across the valve. This results in less pressure recovery, thereby reducing the noise and potential cavitation damage normally generated in standard ball segment models (see fig. 2).

The information above is also available for the KVT LN, KVX LN, KVTF LN and KVXF LN valves.

In addition, these models (LN design) can tolerate media containing a small amount of fibres or particles. Check with SOMAS for information.

Note! The capacity factors for valves of LN design are reduced. Capacity factors and remaining factors for valves with LN-trim are available in the valve sizing program SOMSIZE.

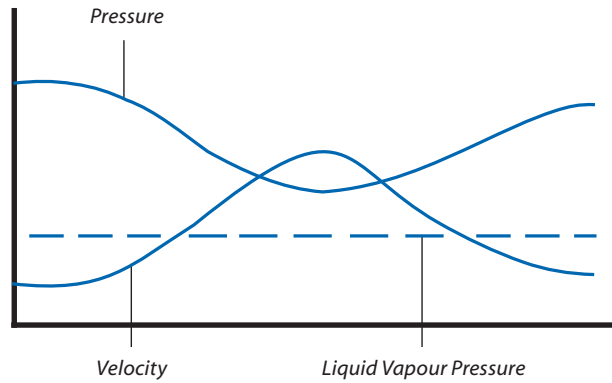

Fig. 2 Pressure and velocity variations with noise reduction trim. Compare with Fig. 1.

### Flow coefficient KVTW LN

Valve DN	Opening angle								
	10°	20°	30°	40°	50°	60°	70°	80°	90°
50	4	14	24	35	46	57	66	72	75
65	6	20	35	51	65	79	89	94	96
80	10	32	54	80	104	129	148	162	170
100	15	47	82	120	156	193	223	244	255
150	28	88	153	225	293	363	417	458	480
200	47	148	257	376	490	608	699	766	800
250	71	223	386	566	737	914	1052	1153	1205

DN 50 - DN 65 = KVT LN

### Flow coefficient KVXW LN

Valve DN	Opening angle								
	10°	20°	30°	40°	50°	60°	70°	80°	90°
50	3	11	20	30	41	50	60	68	70
65	4	15	28	43	58	69	81	89	90
80	7	24	45	69	92	113	134	154	160
100	10	36	67	109	138	171	203	223	243
150	18	68	126	193	260	320	380	435	455
200	30	113	211	322	434	535	636	727	760
250	45	170	318	485	654	806	957	1095	1145

DN 50 - DN 65 = KVX LN

Check with SOMAS (or have a look in the SOMSIZE) to get the flow coefficients for the valves KVTF LN and KVXF LN.



## Further technical information

See the data sheets Si-101, Si-108 and Si-111 for flange standard, technical information and dimensional drawings.

## Valve sizing

Use SOMAS valve sizing program SOMSIZE to find the correct valve size. All sizing factors are included in the program

## Ordering

State desired valve according to the valve specification system below as well as type of actuator, positioner and accessories.

## Actuators and accessories

See the selection tables in the data sheets Si-101, Si-108 and Si-111.

Manually operated actuators are NOT available for LN-valves.

## Valve specification system

**KVTW LN - A 5 - A K A - B 1 2 - DN... - PN...**

**1 Type of valve**

*Wafer design*

KVTW LN (centrically mounted shaft)

KVXW LN (eccentrically mounted shaft)

*Flanged design*

KVTF LN (centrically mounted shaft)

KVXF LN (eccentrically mounted shaft)

KVT LN<sup>1</sup> (centrically mounted shaft)

KVX LN<sup>1</sup> (eccentrically mounted shaft)

**2 Valve body design**

A = Wafer design (DN 50 - 250)

B = Flanged design (DN 80 - 400)

L = Flanged design (DN 50)

**3 Nominal pressure**

3 = PN 16

5 = PN 25

6 = PN 50

**4 Material – valve body**

A = CF8M

**5 Material – ball segment**

K = 1.4460<sup>2</sup>, hard chromed

L = 1.4460<sup>2</sup>, HiCo coated

**6 Material – seat**

A = PTFE (10% carbon)

B = PTFE 53<sup>3</sup>

T = HiCo (High Cobalt alloy)

**7 Material – shaft**

B = 2324-12, hard chromed

E = 2343-12, hard chromed

**8 Bearings – valve body/shaft**

1 = Without bearings

7 = 2562

**9 Stuffing box**

1 = Graphite

2 = PTFE

**10 Valve size, DN**

**11 Drilling, counter flanges, PN/Class**

<sup>1</sup> KVT LN and KVX LN are valid for DN 50 - 65

<sup>2</sup> 2324-12 for DN 65 - 400

<sup>3</sup> 50% PTFE + 50% 1.4435 (316L) powder (percentage by weight)

*SOMAS reserves the right to make improvements without prior notice.*



**SOMAS**<sup>®</sup>  
[www.somas.se](http://www.somas.se)

Box 107  
SE-661 23 SÄFFLE  
SWEDEN

Phone: +46 533 167 00  
Fax: +46 533 141 36  
E-mail: [sales@somas.se](mailto:sales@somas.se)