



application: liquids liquids with solid particles/powders
high viscosity fluids

Piston Valve

Metal-to-metal sealing / Cast design type 606M

Piston valve

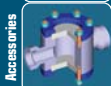
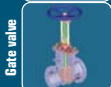
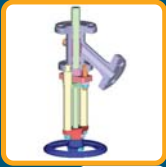

Features

- Stainless Steel cast body (A351 CF8M)
- Polished piston
- Conical metal-to-metal piston seating
- Fixed or interchangeable seat
- Outlet angle: 60°
- Bolted stuffing-box, self adjustable with spring washers, repackable in service
- Rising non turning stem with outside threads
- Position indicator
- Integral connection flanges class 150 to 600
- PED 97/23/EC compliant

Competitive advantages

- Full bore, low pressure drop
⇒ Higher efficiency
- Live loaded (repackable) stuffing box
⇒ Low maintenance
- Polished piston
⇒ Smooth surface, no retention
- Rising non turning piston
⇒ Reduced packing wear



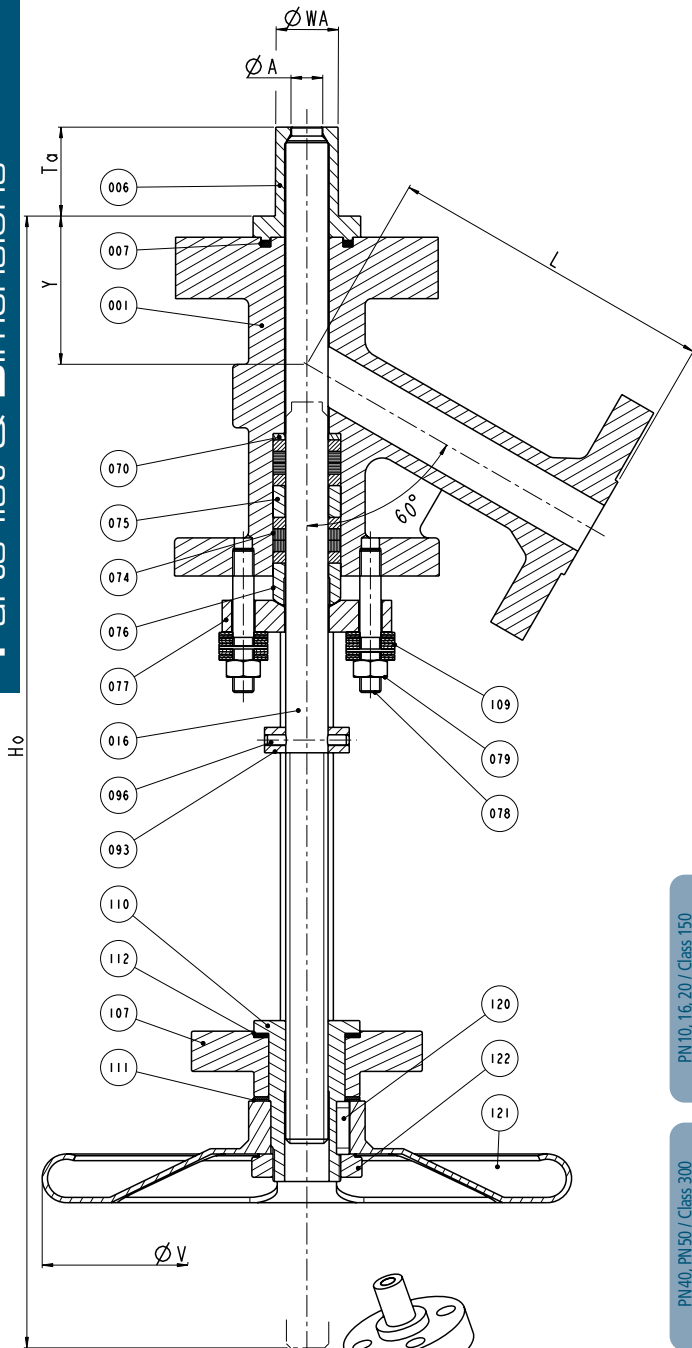

Part n°	Part name	Qty	Material
001	Body	1	A351 CF8M
006	Seat	1	316L
007	Seat gasket	1	Graphite
016	Piston	1	316L
070	Gland bottom ring	1	316L
074	Packing	4	PTFE/silk
075	Lantern	1	316 L
076	Gland	1	316 L
077	Gland flange	1	Stainless Steel
078	Gland stud	2	A 193 Gr.B8M (A4-70)
079	Gland nut	2	A 194 Gr.8M (A4-70)
089	Column	2	Stainless steel
093	Opening indicator	1	Stainless steel
096	Indicator pin	1	Stainless steel
107	Bridge	1	Stainless steel
108	Column nut	2	Stainless steel
109	Spring washer	2	50 CV4
110	Yoke nut	1	303
111	Upper friction washer	1	Celoron
112	Lower friction washer	1	Celoron
120	Handwheel key	1	A56
121	Handwheel	1	Painted steel
122	Handwheel nut	1	Zinc coated steel

Piston Valve
Metal-to-metal sealing / Cast design
type 606M

DN	15	20	25	32	40	50	65	80	100	125	150	200
ØA	15	20	25	32	40	50	64	80	100	125	150	200
Ta	AS REQUESTED BY CUSTOMER											
Øwa(1)	30	36	42	47	57	67	84	98	126	150	175	235
Y	40	45	50	60	60	65	75	85	95	105	125	155
L	130	140	150	160	180	200	220	240	290	330	350	435
ØV	180	180	250	250	300	300	300	400 ⁽²⁾	300 ⁽²⁾	300 ⁽²⁾	300 ⁽²⁾	400 ⁽²⁾
Ho	460	470	570	610	650	710	830	950	1130	1330	1550	1800
W/Kg(3)	10	16	22	24	32	37	53	68	88	163	279	338

DN	15	20	25	32	40	50	65	80	100	125	150	200
ØA	15	20	25	32	40	50	64	80	100	125	150	200
Ta	AS REQUESTED BY CUSTOMER											
Øwa(1)	30	36	42	47	57	67	75	85	95	105	125	155
Y	40	45	50	60	60	65	84	98	126	150	175	235
L	130	140	150	160	180	200	220	240	290	330	350	435
ØV	180	180	250	250	300	300	400	300 ⁽²⁾	400 ⁽²⁾	400 ⁽²⁾	500 ⁽²⁾	600 ⁽²⁾
Ho	460	470	570	610	650	710	850	1090	1180	1390	1600	1850
W/Kg(3)	10	16	22	24	32	37	60	83	95	206	308	445

(1) For removable seat design only

(2) Manual gear

(3) Weights quoted for dimension Ta = 0 mm

OPTIONS

- Other pressure classes, other sizes
- Piston extension on request
- Other materials: austenitic Stainless Steels (304, 321, 904 ...), Duplex, Hastelloy®
- Heating jacket
- Valve welded to pipe insert flange (type 609)
- Counter flange (pad)
- Hard faced seat and/or piston seating surface (stellite)
- Pneumatic, electric or hydraulic actuator
- Manual override
- Cleaning nozzle
- Internal surface Ra >= 0,4 µm
- EN10204 3.1 certificates, ATEX
- ASME, JIS, GOST... standards.

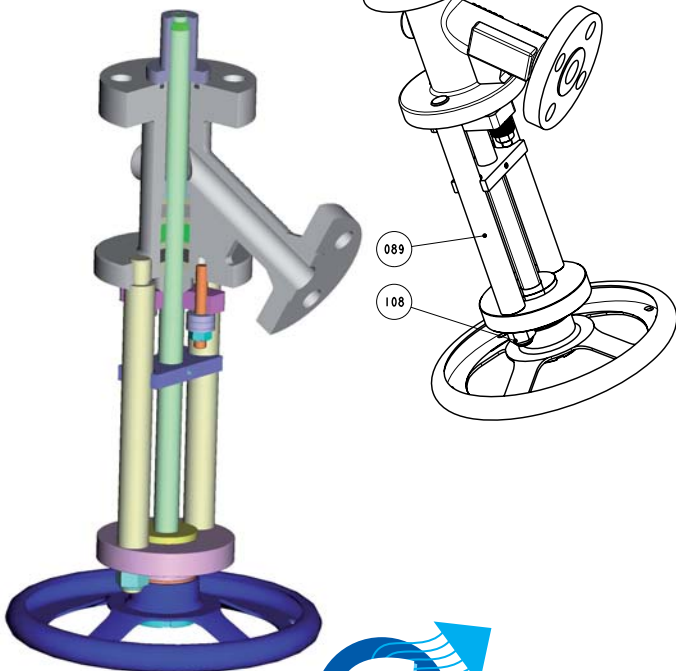

26 rue Paul Girod – Z.I. Bissy • 73000 Chambéry • France
Tél : + 33 (0)4 79 44 59 00 • Fax : + 33 (0)4 79 44 59 01
E-mail : info@guichon.com • www.guichon.com